



Effect Of Flash And Fire Point Determination In Ink Behavior For Screen Printing, Flexography Printing And Gravure Printing

¹Sandeep Gangrade & ²Dinesh Kumar Gupta

^{1,2}Institute for Excellence in Higher Education, Kaliyasot Dam, Kolar Road, Bhopal, M. P. India

E-mail- gangrade.sandeep@rediffmail.com

Abstract

The Flash & Fire point in printing inks play a very important role, as the inks used contains VOC's and having very low flash and fire point. Determination of flash and fire point can give an easy idea of usability of printing inks to specific high temperature without losing its printing quality and lowering solvents evaporation.

Keywords: *Printing inks, printing quality, VOC's.*

1- Introduction

The first inks were reportedly fruit or vegetable juices; protective secretions from cephalopods such as squid, cuttlefish, and octopus; blood from some types of shellfish; and tannin from galls, nuts, or bark from trees. It is believed that the appearance of the first man made ink dates back to 4,500 years in Egypt, which consisted of a mixture of animal or vegetable charcoal (lampblack) and glue. The earliest black writing inks, developed before 2500BC, were suspensions of carbon, usually lampblack, in water stabilized with a natural gum or materials like egg albumen. Modern inks are complex formulations. Along with the pigment, they also contain some additional ingredients collectively known as 'vehicle' in varying levels. These exemplify pH modifiers, humectants to retard premature drying, polymeric resins to impart binding and allied properties, defoamer/antifoaming agents to regulate foam efficiency, wetting agents such as surfactants to control surface properties, biocides to inhibit the fungal and bacterial growth that lead to fouling, and thickeners or rheology modifiers to control ink application. Thus, in other words, printing of one form or the other another has been

there with us for centuries; while the primary functions of decoration and information remain same, the technologies of both the printing process and the ink formulations have changed considerably.

Inks occupy an integral and versatile position in our daily lives. Our day begins on sleepy note with newspapers and toiletries to breakfast table which is replete with several ink labeled, packaged consumer products such as tea or coffee, bread, butter and then gradually moving to our work places schools or offices which have myriad ink laden products be it books, calendars, photocopies, computer prints, stamps or even money, ink is found everywhere. Generally, ink is an organic or inorganic pigment or dye dissolved or suspended in a solvent. However, chemically, it is viewed as a colloidal system of fine pigment particles, colored or un-colored, dispersed in an aqueous or organic solvent.

Today's inks comprise two classes: printing and writing inks. The former is further broken down into two sub-classes: ink for conventional printing, in which a mechanical plate comes in contact with or transfers an image to the paper or object being printed on; and ink for digital nonimpact printing, which includes ink-jet

and electro photographic technologies. Over 90 percent of inks are printing inks, in which color is imparted by pigments rather than the dyes used in writing inks.

2- Materials and Methods

Determination of Flash and Fire point for printing ink is one of the most important parameter in defining the usability of inks to various printing technologies, understanding of Flash and Fire point will give a detailed knowledge about usability of inks to a specific temperature, without this it is very dangerous for the working person on machine to set the temperature for printing. Flash and Fire point determination will also give us knowledge about the working temperature of inks, and with the help of this a machine operator can easily choose the thickness of material to be printed with accuracy. As it is a known fact that printing inks use solvents and many of these solvents are volatile organic compounds in nature and their flash and fire point depend upon the concentration of these solvents, a prior knowledge is must for proper functioning and print quality of print matter.

The flash point is one measure of the tendency of the test specimen to form a flammable mixture with air under controlled laboratory conditions. It is only one of a number of properties that should be considered in assessing the overall flammability hazard of a material. Flash point is used in shipping and safety regulations to define flammable and combustible materials. Flash point can indicate the possible presence of highly volatile and flammable materials in a relatively non-volatile or non-flammable material. This test method shall be used to measure and describe the properties of materials, products, or assemblies in response to heat and a test flame under controlled laboratory conditions and shall not be used to describe or appraise the fire hazard or fire risk of materials, products, or assemblies under actual fire conditions. However, results of this test method may be used as elements of a fire risk assessment that takes into account all of the factors that are pertinent to an assessment of the fire hazard of a

particular end use. The fire point is one measure of the tendency of the test specimen to support combustion.

This test method describes the determination of the flash point and fire point of test sample by a Pensky Marten's apparatus. Fire point is a parameter that is not commonly specified, although in some cases, knowledge of this flammability temperature may be desired.

Apparatus Required: Flash and fire point apparatus, match box, thermometer, and filter paper.

Principle; Flash point is the lowest temperature at which the lubricating oil gives off enough vapors that ignite for a moment when tiny flame is brought near it. Fire point is the lowest temperature at which the vapors of the sample burn continuously for at least five seconds when a tiny flame is brought near it. Significance Flash and fire points are used to indicate Fire hazard of products and evaporation loses under high temperature loses, it gives us the idea about the maximum temperature below which the product can be used.

Description of Pensky Marten's Apparatus; It is used to determine the flash point of the sample, solvents, containing material and suspension of solids. It consists of three parts

(a) Sample Cup: Material Brass, Height 5.5cm, Diameter 5cm, Lid of the cup is provided with four openings of standard sizes, first opening is for stirrer, second is for admission of air, third is for thermometer and fourth is for introducing test flame.

(b) Shutter: At the top of the cup shutter is provided. By moving the shutter, opening in the lid opens and flame is dipped in to this opening, bringing the flame over the oil surface. As the test flame is introduced in the opening, it gets extinguished, but when the test flame is returned to its original position, it is automatically lightened by the pilot burner.

(c) Stove: It consists of Air bath, top plate on which the flange of the cup rest.

(d) Cup: The cup shall be of brass, or other non rusting metal of equivalent heat conductivity.

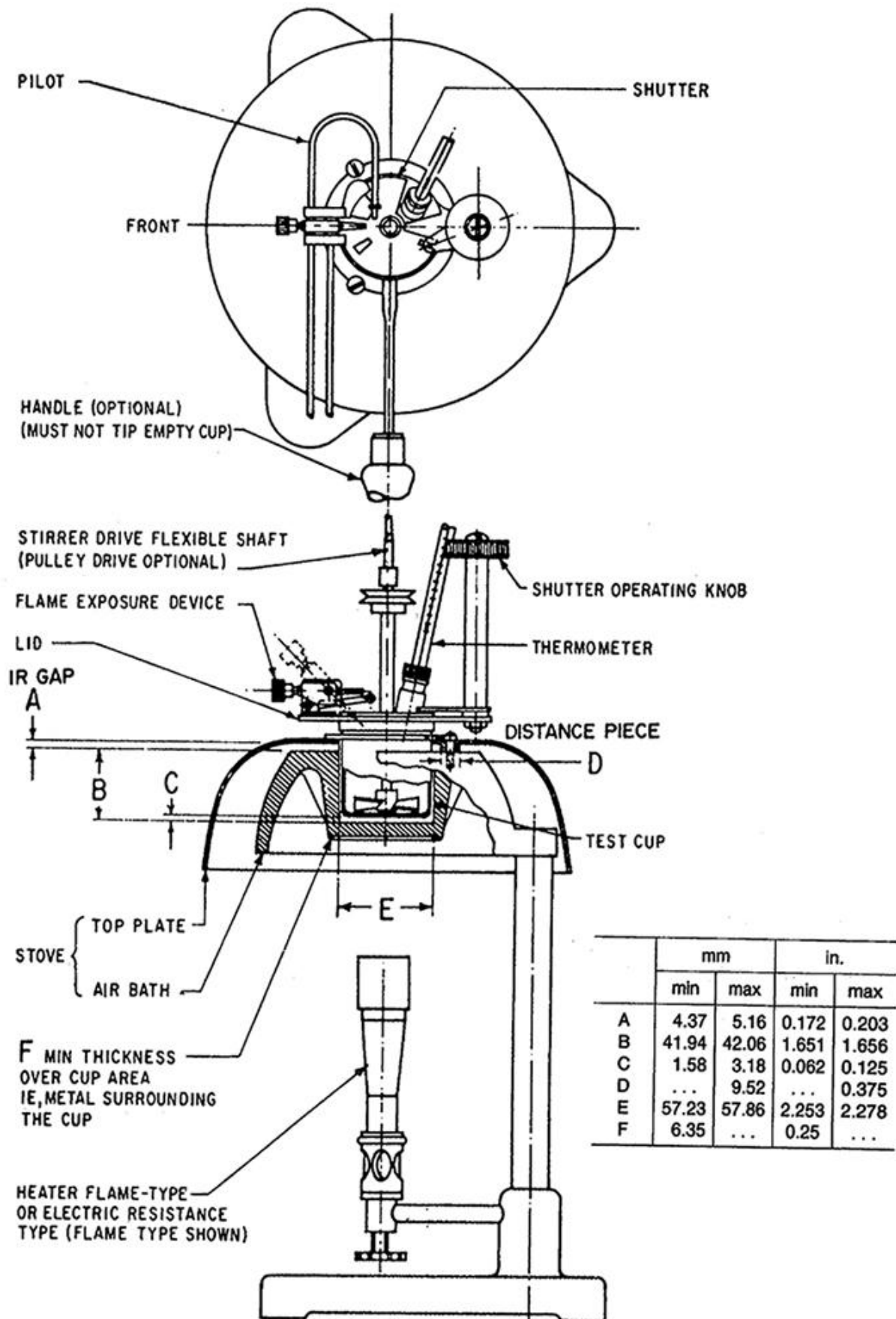

NOTE 1—Lid assembly can be positioned either right or left-handed.

Pensky-Martens Apparatu

Procedure Clean and dry all parts of the apparatus with the help of suitable solvent e.g. CCl₄, ether, petroleum spirit or benzene and dry it to remove any traces of solvent. Fill the cup with the test sample up to the mark. Fix the lids on the top through which are inserted a thermometer and a stirrer. Ensure that the flame exposure device is fixed on the top. Light the test flame and adjust it to about 4 mm in diameter. Heat apparatus as temp. of sample increases by 5 to 6^o per min. as stirrer is continuously rotated. At every 5^o C rise of temp. Introduce test flame into the sample vapor. This is done by operating the shutter. On moving knob of shutter, test flame is lowered in sample vapors through opening. When test flame causes a distinct flame in interior cup, note temp. which represent the flash point.

Further heat the sample at the rate of 1^oC/min. and continue applying the test flame as before. The temperature at which the vapors of the sample give a clear and distinct blue flash for five seconds is recorded as the fire point of the sample.

3- Results and Discussion

For determination of Flash and Fire points of Letter Press and Lithography Printing technique all four colour inks were used they are Cyan Ink, Magenta Ink, Yellow Ink and Black Ink. With the help and Flash and Fire point apparatus their flash and fire point were noted. Results clearly indicate that there has been a remarkable effect of temperature on ink performance and its usability, the results clearly indicates the safe temperature to which a user can use the inks under safe temperatures.

FLASH AND FIRE POINT MASTER TABLE

Sample Number	Printing Technology	Ink Colour Type	FLASH POINT		FIRE POINT	
			°C	°F	°C	°F
Sample – 1	Screen Printing	Cyan Ink	78.2	172.7	81.8	179.2
Sample – 2	Screen Printing	Magenta Ink	75.3	167.5	77.4	171.3
Sample – 3	Screen Printing	Yellow Ink	73.1	163.5	76.3	169.3
Sample – 4	Screen Printing	Black Ink	74.2	165.5	79.7	175.4
Sample – 5	Flexography	Cyan Ink	79.1	174.3	83.7	182.6
Sample – 6	Flexography	Magenta Ink	81.4	178.5	85.7	186.2
Sample – 7	Flexography	Yellow Ink	79.5	175.1	82.4	180.3
Sample – 8	Flexography	Black Ink	83.1	181.58	85.7	186.2
Sample – 9	Gravure	Cyan Ink	81.8	179.2	84.2	183.5
Sample – 10	Gravure	Magenta Ink	75.2	167.3	78.5	173.3
Sample – 11	Gravure	Yellow Ink	73.5	164.3	77.7	171.8
Sample – 12	Gravure	Black Ink	83.2	181.76	89.4	192.92

GRAPH FOR SAMPLE NO. 01

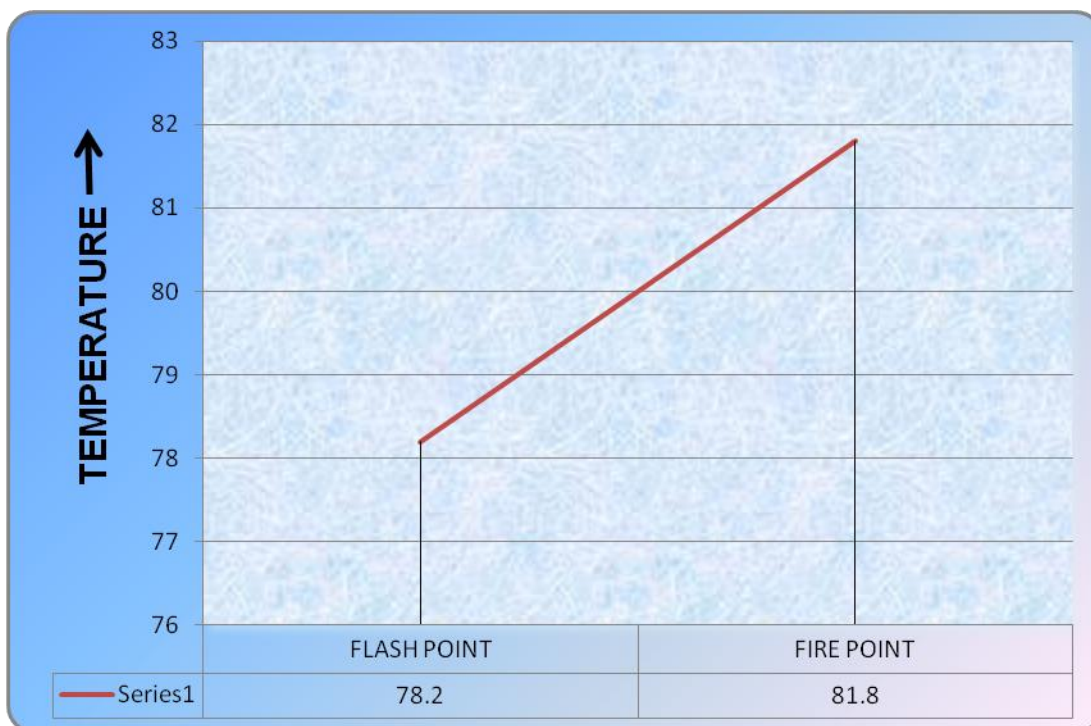

GRAPH FOR SAMPLE NO. 02

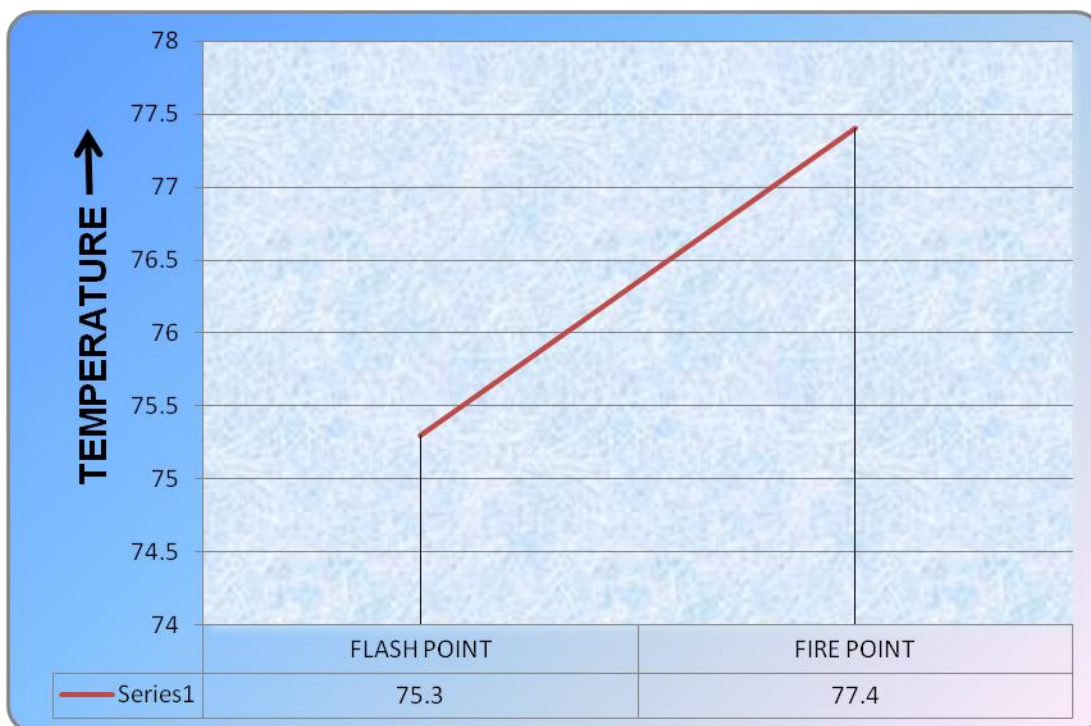

GRAPH FOR SAMPLE NO. 03

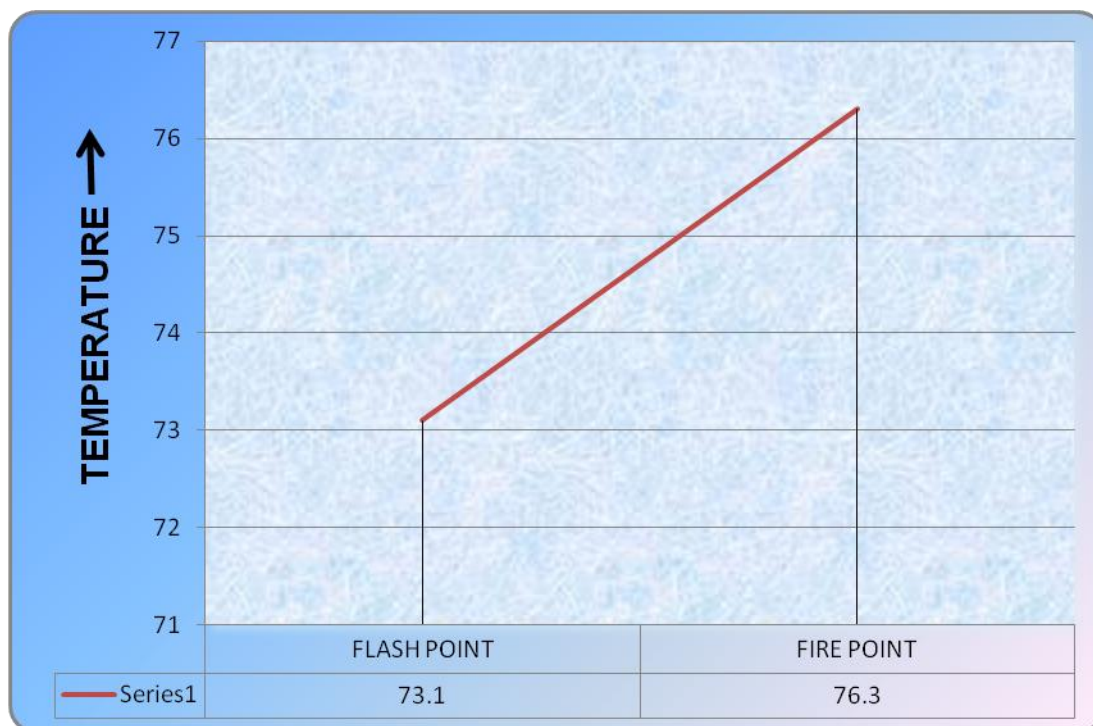

GRAPH FOR SAMPLE NO. 04

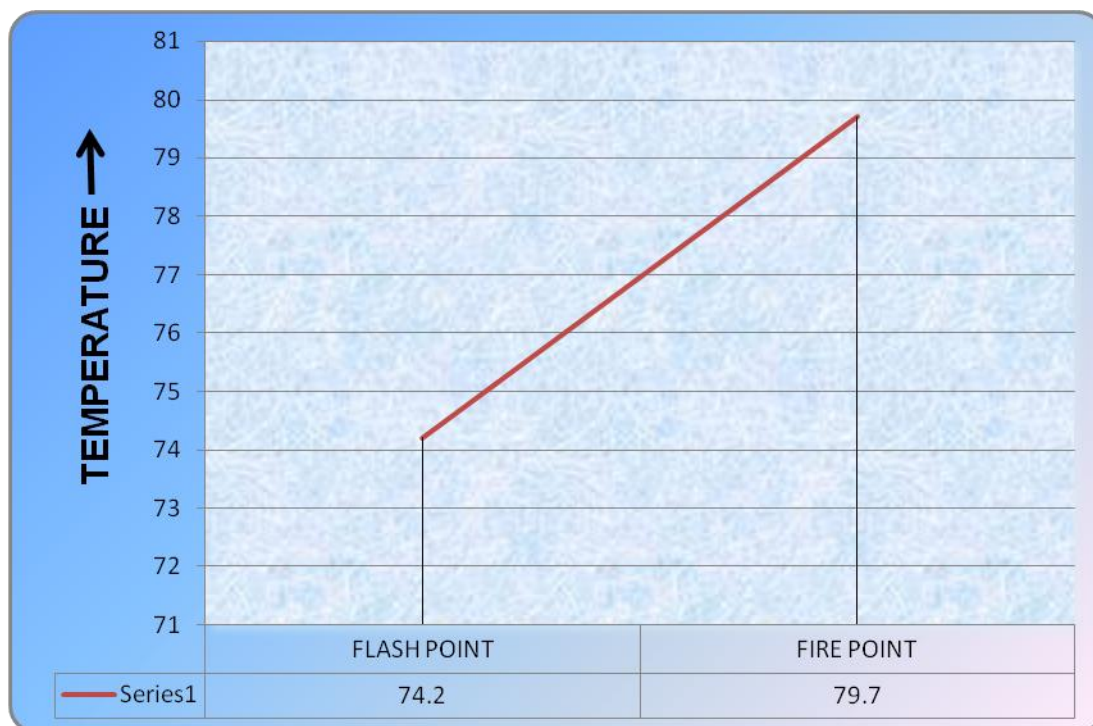

GRAPH FOR SAMPLE NO. 05

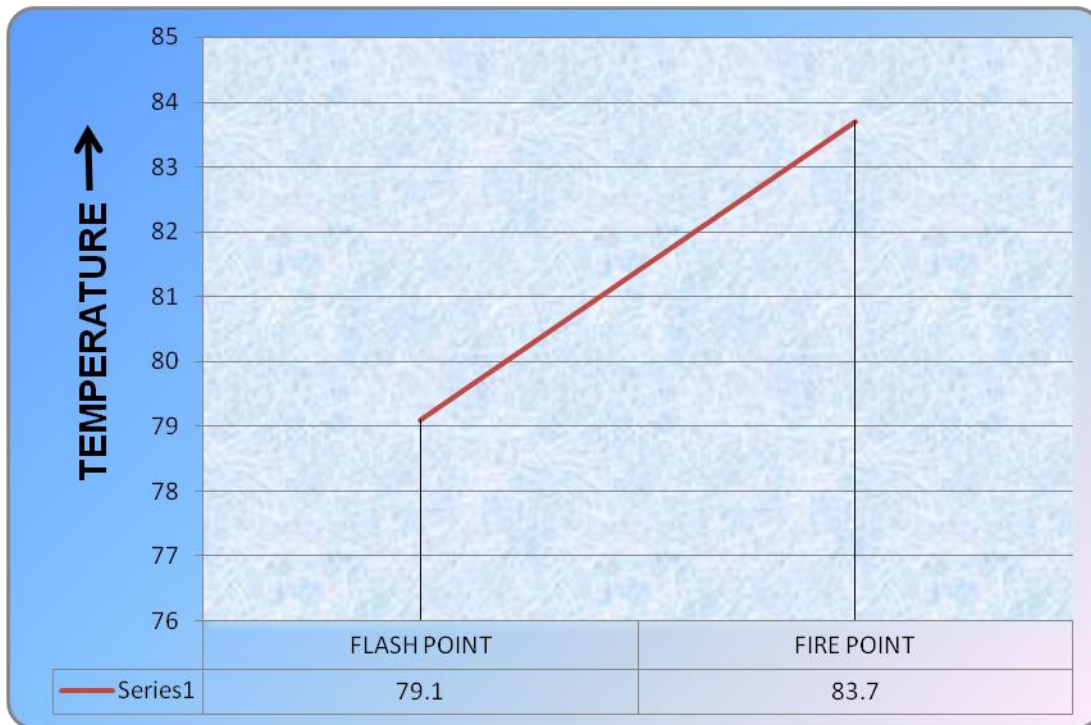

GRAPH FOR SAMPLE NO. 06

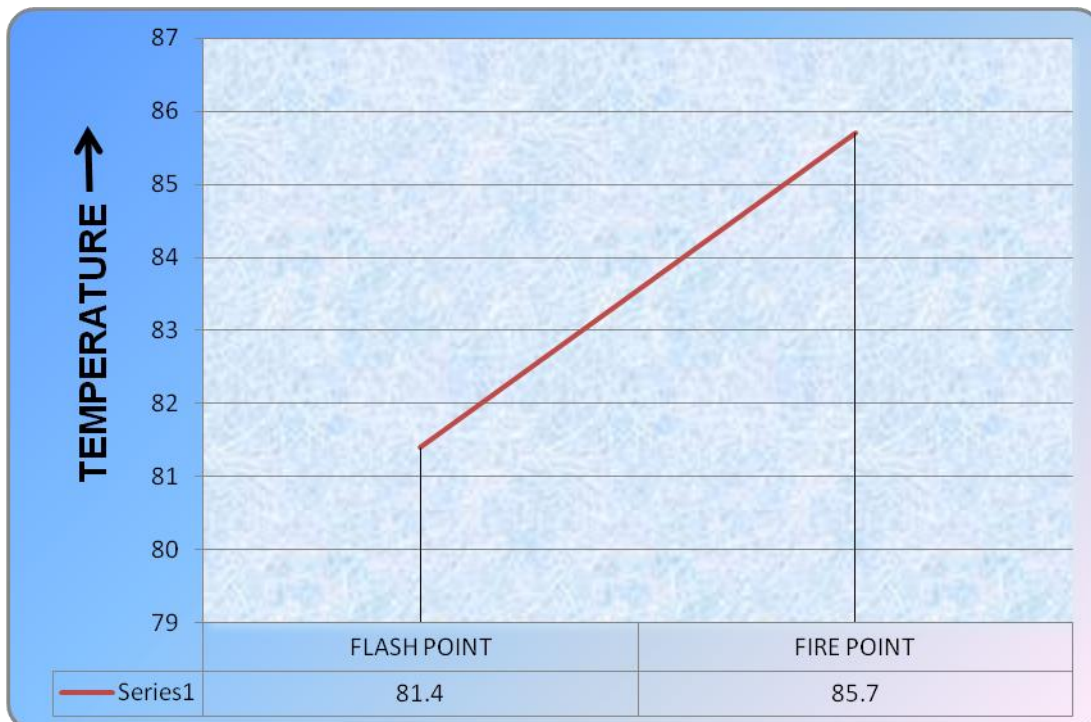

GRAPH FOR SAMPLE NO. 07

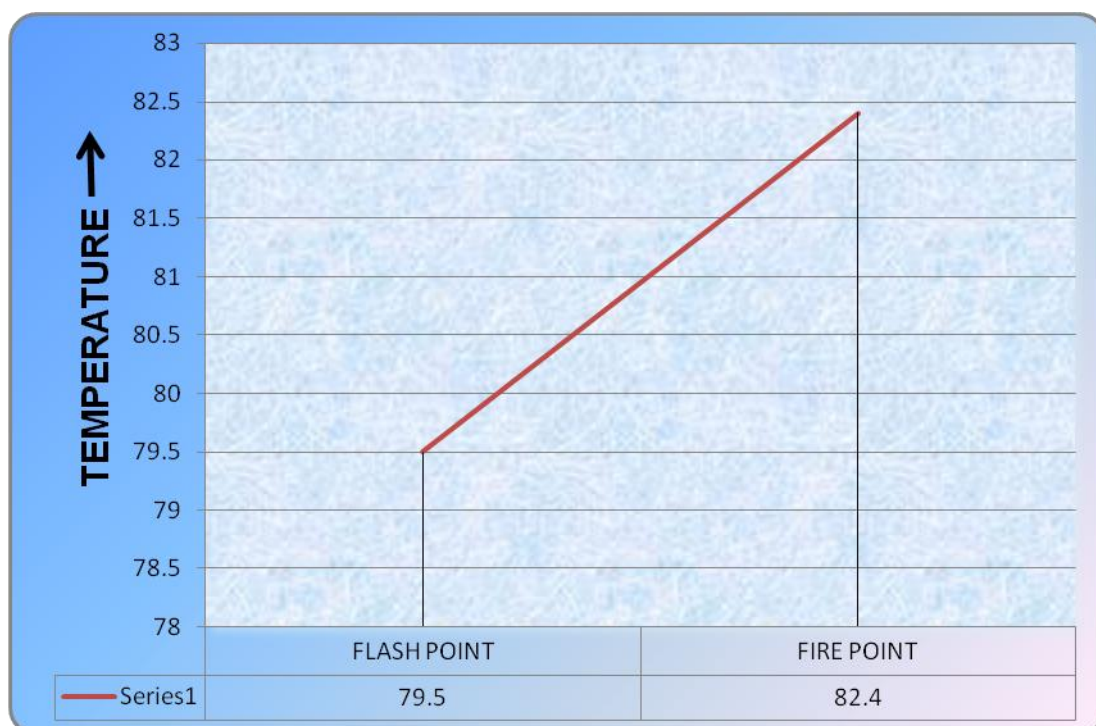

GRAPH FOR SAMPLE NO. 08

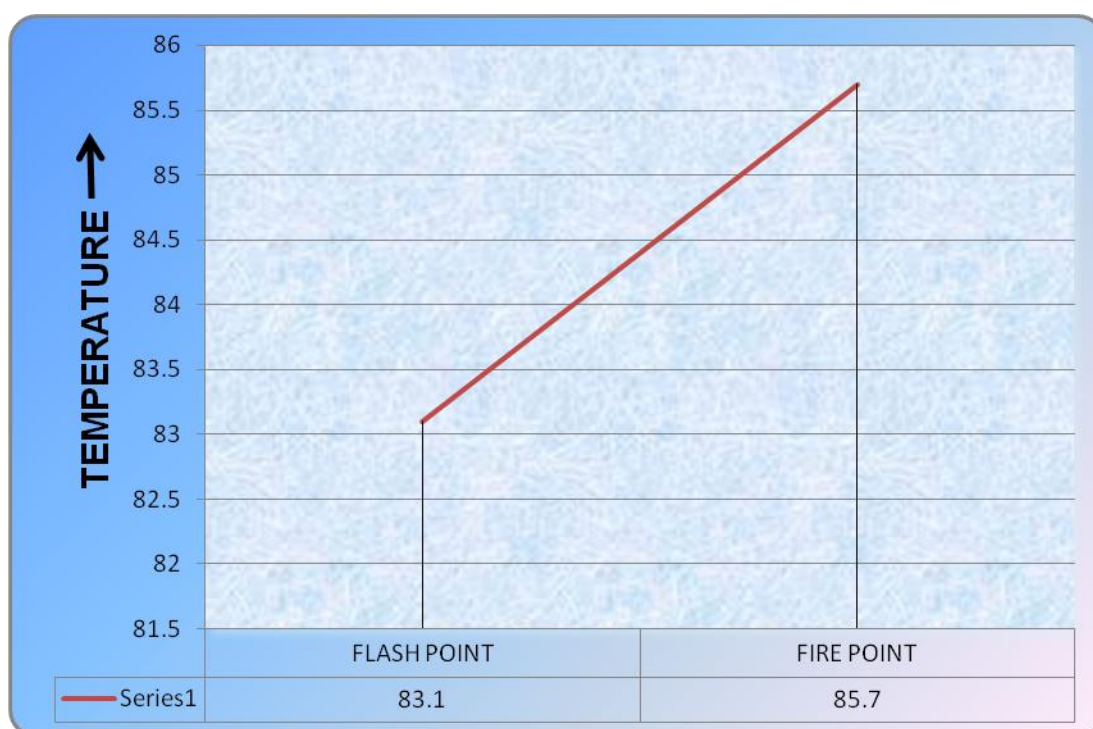

GRAPH FOR SAMPLE NO. 09

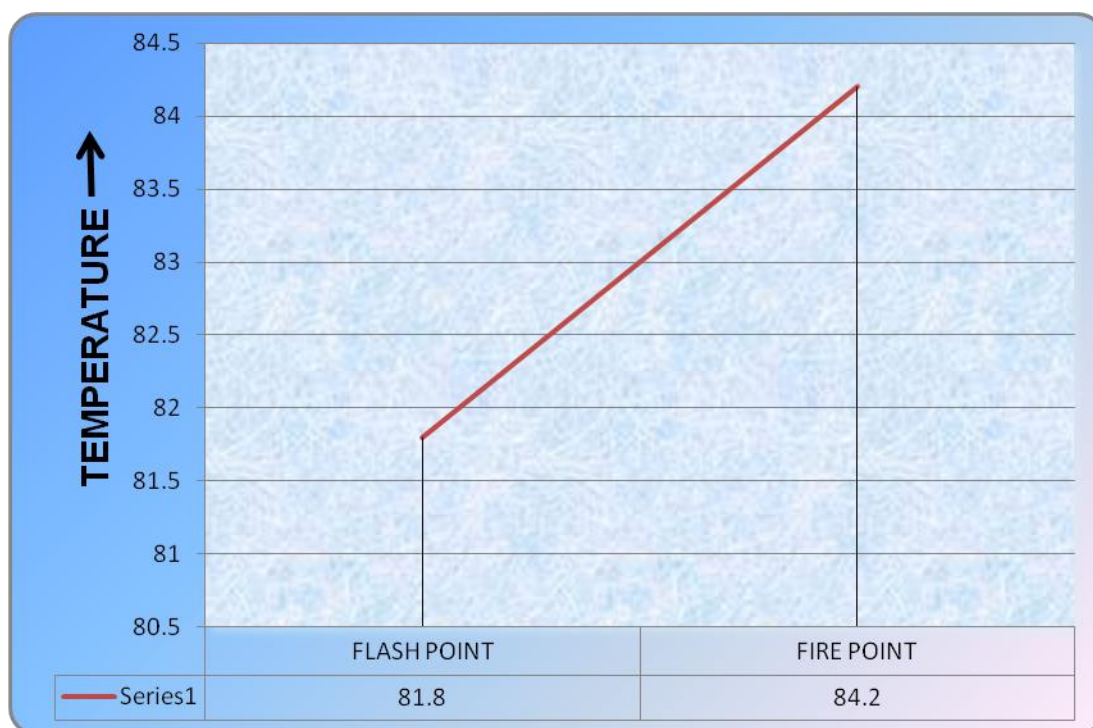

GRAPH FOR SAMPLE NO. 10

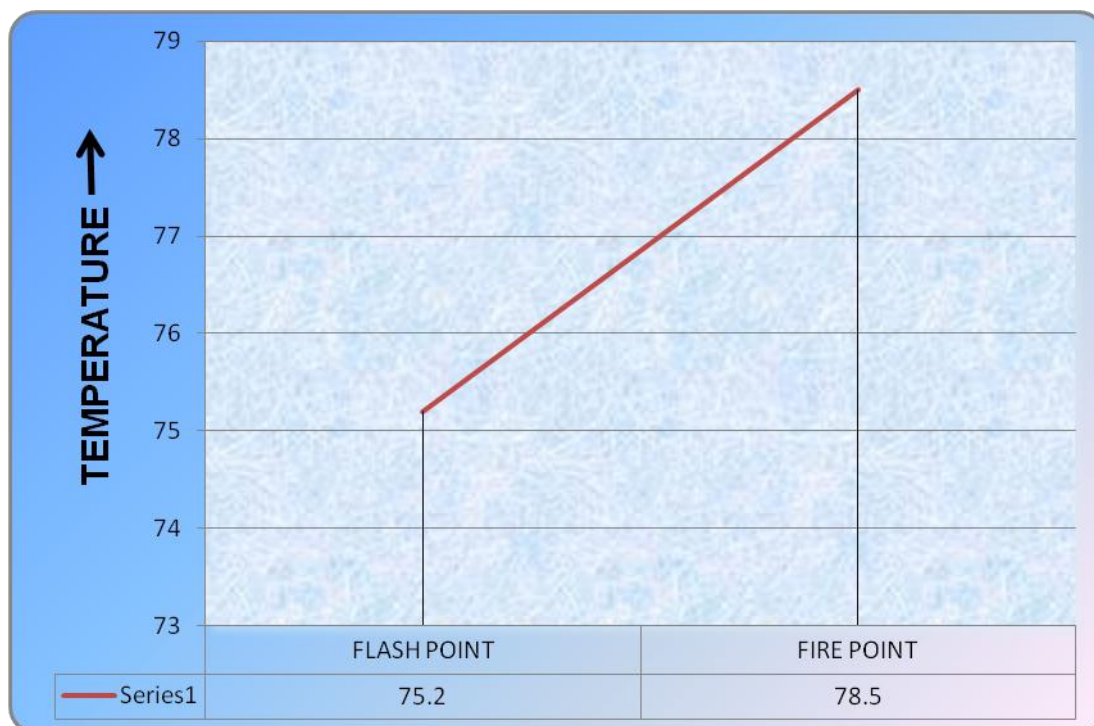

GRAPH FOR SAMPLE NO. 11

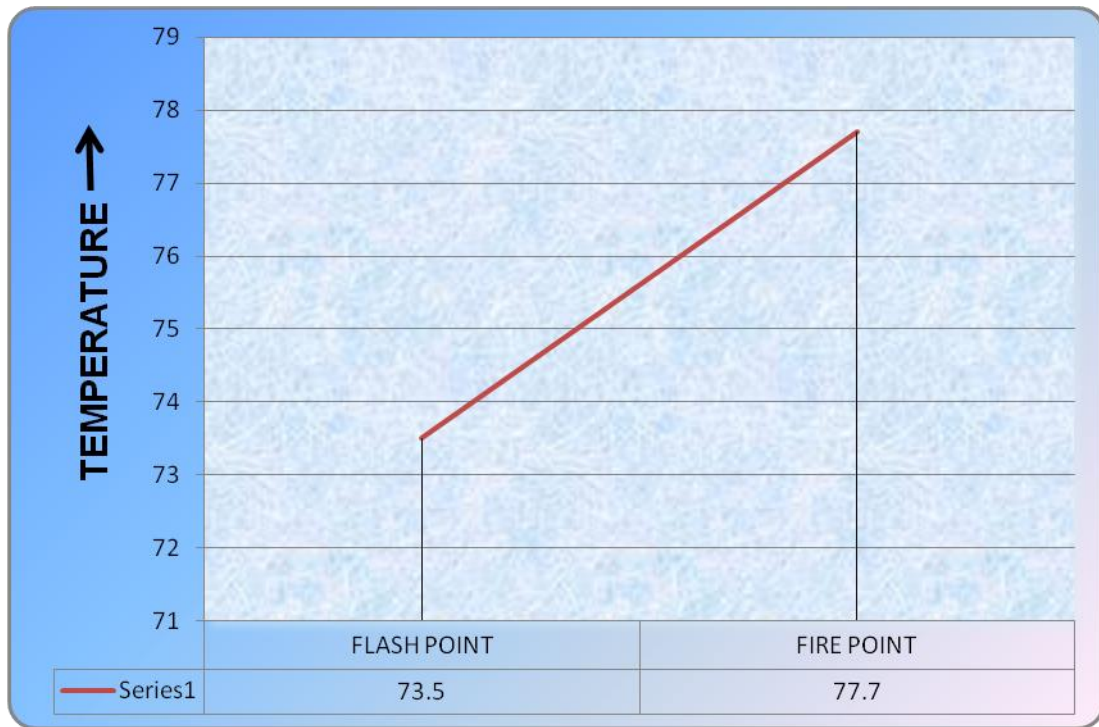

GRAPH FOR SAMPLE NO. 12

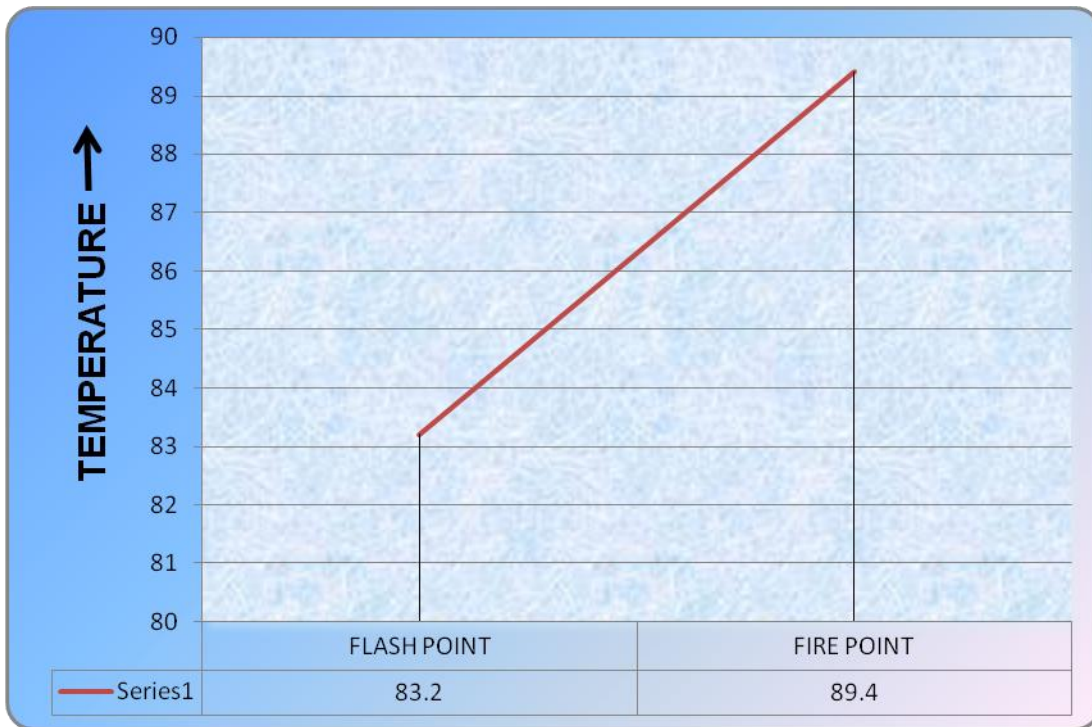

4- References

1. Kipphan, Helmut (2001), Handbook

of print media: technologies and production methods (Illustrated ed.),

- Springer, pp. 130–144,
2. American Society for Testing and Materials, Standard practice for determining limits of flammability of chemicals at elevated temperature and pressure, ASTM E 918, 1983
 3. F.P. Bodhurtha, Industrial Explosion Prevention and Protection, McGraw-Hill Inc., N. Y., 1980.
 4. D.A. Crowl, J.F. Louvar, Chemical Process Safety, Fundamentals with Applications, Prentice Hall, Englewood Cliffs, 1990
 5. Ainsworth, Mitchell, C., "Inks and Their Composition and Manufacture," Charles Griffin and Company Ltd, 1904
 6. Society of British Printing Ink Manufacturers Ltd. 1993. The Printing Ink Manual. 5th edition.
 7. Bamber Gascoigne: How to Identify Printing Complete Guide to Manual and Mechanical Processes from Woodcut to Inkjet (ISBN 0-500-28480-
 8. Ainsworth, Mitchell, C., "Inks and Their Composition and Manufacture," Charles Griffin and Company Ltd, 1904
 9. Zumdahl, Steven S. (2009). Chemical Principles 6th Ed. Houghton Mifflin Company. p. A23. ISBN 0-618-94690-X
 10. Thomas Franklin Carter, The Invention of Printing in China and its Spread Westward, The Ronald Press, NY 2nd ed. 1955, pp. 176–178.
 11. Man, John (2002). Gutenberg: How One Man Remade the World with Words. New York: John Wiley and Sons, Inc. ISBN 0-471-21823-5.
 12. Tsien Tsuen-Hsuei; Joseph Needham (1985). Paper and Printing. Science and Civilization in China. 5 part 1. Cambridge University Press. pp. 158, 201.
 13. Wood, s. (1994) The history of Printing Inks, Prof. Printer, 38, 12-17.
 14. The Franklin Institute Inc. "Blood – The Human Heart". Retrieved 19 March 2009.
 15. Alberts, Bruce (2012). "Table 22-1 Blood Cells". Molecular Biology of the Cell. NCBI Bookshelf. Retrieved 1 November 2012.
 16. Elert, Glenn and his students (2012). "Volume of Blood in a Human". The Physics Fact book. Archived from the original on 2012-11-01. Retrieved 2012-11-01.
 17. Sugio, S.; Kashima, A.; Mochizuki, S.; Noda, M.; Kobayashi, K. (1 June 1999). "Crystal structure of human serum albumin at 2.5 Å resolution". Protein Engineering Design and Selection 12 (6): 439–446.